

Model RH-200 Relative Humidity Generator *Easy to Use – Precision Humidity Control*

The Model RH-200 RH Generator is a fully automated, compact and portable bench-top instrument which easily and quickly interfaces with other laboratory systems to provide a specified constant flow of gas at a precision-controlled relative humidity.

Features/Specifications of the RH-200

- Integrates with laboratory instruments such as X-ray diffractometers, TGA, TMA, DMA and calorimeters and also with glove boxes, environmental chambers and more
- Relative humidity range from 2% to 98% with precision-controlled accuracy of RH to $\pm 1.0\%$
- Flow rates up to 500 sccm are standard with optional ranges available up to 50 liters/min
- Provides gas stream with controlled RH and flow for desired temperature from ambient to 80°C at the target instrument
- Compact design with 8" wide x 14" deep footprint
- Customizable options are available to meet a broad range of applications - see reverse side

Instrument Details

- Two precision mass flow controllers regulate the flow of dry air and saturated air
- Dual-stage chilled-mirror Dew Point Analyzer provides stable, accurate RH measurement
- Thermostated enclosure within the RH-200 holds key components at desired constant temperature from ambient to 50°C
- All connections are 1/4" (6 mm) Swagelock fittings
- External automatic water reservoir uses gravity-fed technique and has no moving parts
- RH-200 has a footprint of 8" wide x 14" deep with height of 14"
- Additional space is required for optional computer. Complete facilities and utilities requirements are provided with the instrument

Software/Computer Details

- L&C provides complete software with capabilities for user defined protocols including step variants in both temperature and relative humidity
- Lab Windows USB software from National Instruments with on-line graphics. Software is compatible with Windows 7, 32 and 64-bit versions and Windows 10
- An L&C-supplied computer is available as an option



RH-200 Bench-Top Generator
with footprint 8" wide by 14" deep.

RH-200 Generator

This unique instrument is designed for fully automated operation via user's computer or a computer provided by L&C as an option. Complete software is provided by L&C and all required computer hardware specifications are detailed. The RH-200 is a compact, bench-top instrument, allowing for convenient set-up and operation. It can be flexibly used at various locations within the research laboratory to provide a precise air or nitrogen stream of desired %RH to a wide range of target systems. These include laboratory instruments such as X-ray diffractometers, TGA, TMA, DMA, atomic force microscopes, nano-materials testing equipment, calorimeters, micro-calorimeters and laboratory apparatus such as glove boxes and environmental chambers.

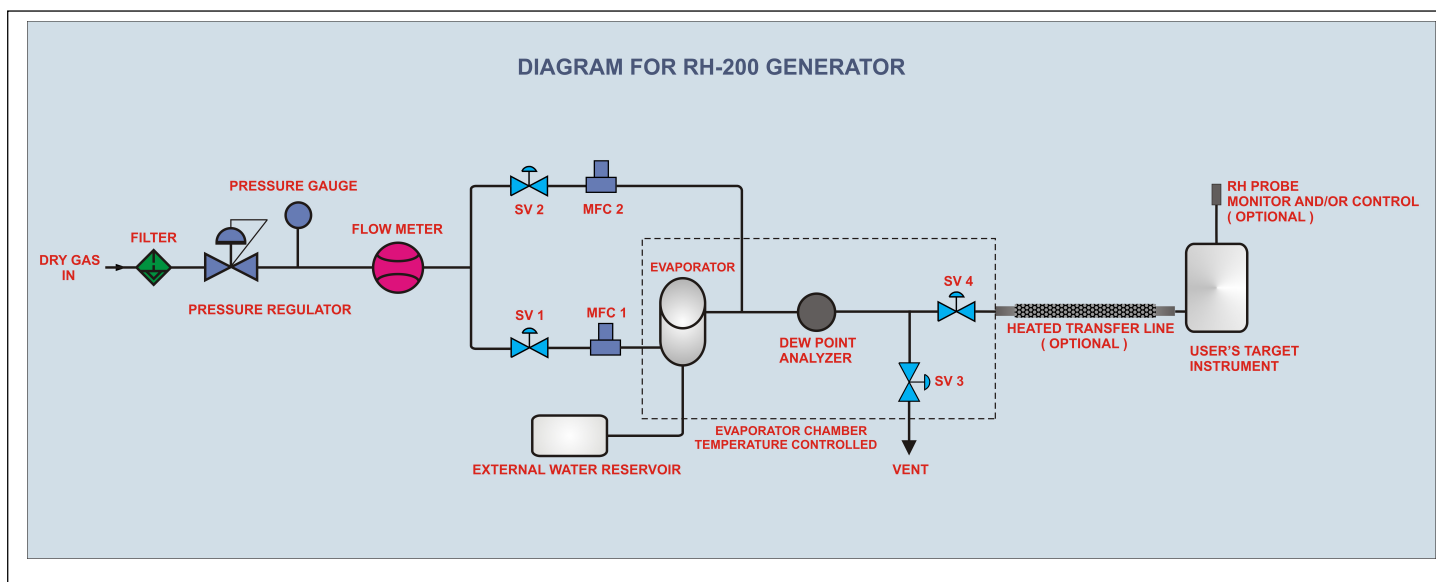

Principles of Operation of the RH-200 Generator

A dry air or nitrogen supply is connected to a port on the rear panel of the RH-200. The input gas flows through a 2 μ filter and a pressure regulator mounted on the front panel. An input pressure gauge and flow meter are also provided on the front panel.

The gas flow is then split into wet and dry paths. The wet stream passes through a mass flow controller (MFC) and enters an Evaporator, where it is saturated with water. The dry stream goes through a second MFC and combines with the wet gas at the output of the Evaporator. The resulting gas mixture passes through a chilled-mirror, dew point analyzer (DPA) and is then directed via a port on the RH-200's rear panel to the target device where the controlled %RH gas stream is desired. Via the mass flow controllers, Windows™ software precisely controls the wet and dry streams to create the desired flow and %RH level, while the DPA monitors the output.

Customizable Options for the RH-200

- **Heated Transfer Lines** to meet the researcher's requirements: *To avoid condensation, a heated transfer line is required for effective use of the RH-200 Generator.* L&C offers optional Heated Transfer Lines to provide adjustable temperature control of the gas stream from the RH-200 Generator to the target instrument. This system includes the transfer line itself, line heater, thermocouple and temperature controller.
- **Probe Interface Kit:** This option provides a remote sensor to interface the RH-200 to the target instrument. The sensor is located at the target system for monitoring and/or controlling purposes...recording/controlling the delivered %RH and temperature through the RH-200 software. The Probe Interface Kit includes the remote probe with housing. Probe has range of 0 to 100% RH, a measurement accuracy of $\pm 1.5\%$ RH and operating temperature range of -40°C to 100°C .